

RESEARCH ARTICLE

Community-Based Enterprise (CBE) Export Performance Strategy: An Analysis of Thailand's Entrepreneurial OTOP Program

Vipada Sitabutr and Samart Deebhijarn

King Mongkut's Institute of Technology Ladkrabang, Thailand
ajarnvipada@gmail.com

Abstract: The concept of community-based enterprises operated by small entrepreneurial groups involved in export of locally manufactured and produced products has become a globally recognized way to relieve rural poverty and urban flight. However, the factors involved in export performance strategies are less defined and can vary significantly from country to country. Production capacity for export purposes is a great challenge for developing nations, which in turn influences the quality, service standard, and production scale. Also, customer satisfaction with goods and service act as critical components to export performance. It was, therefore, the intent of this study to identify the factors and their interrelationships in Thailand's globally recognized "One-Tambon, One-Product" (OTOP) government-sponsored export program. The main research instrument, which measured the five latent variables and 26 observed variables was a questionnaire containing a 6-point unipolar scale to measure the opinions of the 500 exporter/manufacturer sample to the survey's items. To access the measurement model, a confirmatory factor analysis (CFA) was employed using LISREL Version 9.1 prior to the use of a structural equation model (SEM) to analyze the 8-hypotheses model. Results supported similar studies in which it has been determined that product quality plays a key role in the export customer's trust, which has a positive impact on distribution satisfaction. Top down management policies and pricing strategies, however, appear to be limiting factors to an OTOP exporter's success. Finally, future focus should be given to Thai OTOP village cluster competitiveness, in which greater emphasis needs to be given to basic management training, leadership skills, product standardization, maintaining uniform output, understanding costs, and cash flows.

Keywords: microenterprise, OVOP, product quality, satisfaction, trust

A key strategy of the Thai government in 2017 has been to help "grass roots" level, community-based enterprises (CBEs) promote their home-grown agricultural and handicraft products into larger, export-focused, SMEs (small medium sized enterprises). Thais' exhibit remarkably high rates of entrepreneurship, with equal levels of male/female involvement. SMEs

today make up 98.5% of Thailand's businesses, with e-commerce SME's contributing over 30% to total exports (Phetcharat, 2017).

Thailand, however, is not the only Southeast Asian nation relying on SME's for growth. Vietnam has reported that the country currently has more than 500,000 SMEs, which are responsible for 50% of

gross domestic production (GDP), 33% of the state budget, and over five million jobs (Lai, 2017). SMEs in Indonesia are also the backbone of Southeast Asia's largest economy, whose existence has been shown to drive the wheels of the economy and reduce the number of unemployment. Statistics in 2010 showed that there are 3.8 million SMEs, which were spread throughout Indonesia and absorb approximately 8.75 million workers and contribute 32% to the GDP (Fauji & Utami, 2013). Also, according to the Organisation for Economic Co-operation and Development (OECD), SMEs comprise 99.6% of all registered business in the Philippines, and employ 70% of the workforce, which could be why the OTOP program was "re-booted" in 2017 (Cagalitan, 2017).

These countryside communities, however, are becoming less viable due to Thailand and others following the global trend of 54% urbanization of the world's population. Therefore, methods and ideas must be sought and encouraged to stem the wave of poverty and economic hardship that these community migrations entail (Liu & Li, 2017). With rural decline being a global issue, Thailand has for many years been focused on the development and the sustainability of the rural regions and their citizens, which became official government policy with the release of the Eighth National Economic and Social Development Plan (NESD 1997–2001) which included the King of Thailand's "Theory of Economic Self-Sufficiency" (Poungsuk, Pourpan, & Thongsuk, 2016; Prayukvong, 2007). Therefore, engaging locals is the key to rural success (Liu & Li, 2017), with bottom-up initiatives acting as a "social glue," encouraging people to work together (Li, Westlund, Zheng, & Liu, 2016), with community-based development revitalizing community solidarity (Suindrmedhi, 2016).

For example, in 2012, the Xiaoguan village committee in China's northern Hebei province set up a share-based cooperative for breeding sheep and cultivating vegetables. Participants pooled money, land, laborers, and machinery. In just five years, the two businesses increased residents' per capita net income by 200%.

A similar program which has gained increased importance in Thailand and elsewhere, is the OTOP production, branding, domestic sales, and exporting

schemes, which the Thai Commerce Ministry currently indicates represents over 10% of Thailand's exports, and in 2016 represented nearly \$US3 billion (Changson, 2015).

OTOP History

The emergence of the Asian financial crisis in mid-1997 redirected many Asian governments to strengthen their SMEs (Moha-Asri, 2002), with Thailand adopting Japan's "One Village One Product" (OVOP) concept and implementing it in 2001 with a Thai government managed, top-down driven scheme, which was different that the Japanese OVOP program's bottom-up initiatives.

Japan's OVOP began in 1979 in Japan's poorest prefecture (Oita) by the Governor Morihiko Hiramatsu, who adopted the slogan "Think globally, act locally" (Prayukvong, 2007). Hiramatsu's OVOP stressed the importance for locals to lessen their dependence on government subsidies, while helping with retaining youth and improving the quality of life (Prayukvong, 2007; Anh, 2013).

Being relabeled in Thailand as "One Tambon, One Product" or OTOP, the Thai word "Tambon" when translated into English means "sub-district," which is the third smallest administrative unit below district and province in Thailand. Numbering 7,256 tambons throughout Thailand (Hörstemeier, 2017), the program exploded after its inception, growing from a little over \$US7 million in 2001 to \$US2.24 billion in 2008 (Figure 1) (Natsuda, Wiboonpongse, Cheamuangphan, Shingkarat, & Thoburn, 2011).

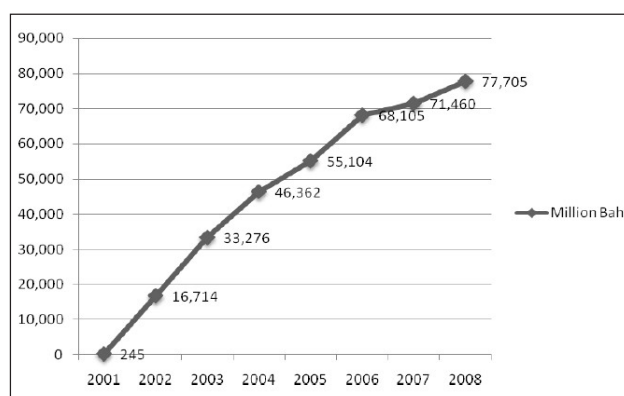

Figure 1. Thailand's OTOP program "early years" from 2001–2008 (Natsuda et al., 2011).

It was not long after OTOP's launch that confirmation of its importance came in 2003 during a 20-nation Asia-Pacific Economic Cooperation (APEC) Ministerial SME Meeting held in Chiang Mai, Thailand. After the meeting, a ministerial statement was issued proclaiming that Thailand's OTOP promotion was a good model entrepreneurial society development, especially in local areas (Asia-Pacific Economic Cooperation, 2003).

Even the United Nations Industrial Development Organization (UNIDO) in 2008 released a report committing itself to rural development and poverty reduction in Africa using an OVOP/OTOP-type project style (Haraguchi, 2008), while other developing nations around the world have adopted both Governor Hiramatsu's and Thailand's visions, including China, Malawi, South Africa, Laos, and the Philippines (Liu & Li, 2017).

During this early period, it was the Thai Department of Rural Community Development which was the coordinating office, and which also selected the champion product at all administrative levels with the selection criteria focused on: 1) export potential, 2) maintaining quality production, 3) high production standards which contributed to product quality and customer satisfaction, and 4) the product's history (Prayukvong, 2007). Additionally, a rating system of one to five was implemented, with five stars being necessary for export potential.

Government Support

The government plays a supporting role as well, assisting in supply chain issues, consultation with enterprise entrepreneurs, networking, and opening up new markets for the OTOP products. As an example, in 2016, the national flag airline Thai Airways included 128 OTOP products in their in-flight catalog (National News Bureau of Thailand, 2016). Additionally, OTOP products are to be sold at each of Thailand's 28 airports under the authority of the Department of Airports. Considering that in 2016, 122 million air travelers transited Thailand's airports (Kositchotethana, 2017), this represents a huge potential for future domestic sales of OTOP products. OTOP shops are also being established in each of the two national gas stations

(PTT) in each province, with OTOP fairs and booths now common throughout all of Thailand.

The basic idea of the OTOP scheme is to have each Tambon (sub-district) concentrate on one certain type of product which is best suited for production in each sub-district. Presently, approximately 40% of the Thai OTOP enterprises are engaging in food processing and handicraft production, with a heavy concentration of the enterprises in Thailand's northern provinces. Product categories recently identified as export rising stars include processed foods and beverages, utensils, decorative items and souvenirs, cloth, apparel, and accessories (Changson, 2015).

In a 2015 research from the Thailand Productivity Institute, it was indicated that there were approximately 70,000 OTOP enterprises registered country-wide (Changson, 2015), and according to the Thai Interior Ministry's Community Development Department, 10,000 of these have been granted a "5-star" rating. It is the 5-star rating which qualifies the enterprise to export, and in 2015, 5,687 exporters were generating more than US\$2.88 billion yearly in foreign revenue for Thailand (Changson, 2015).

Many community-based enterprises and entrepreneurs have aspirations to become small-medium enterprises and one mechanism to achieve this is to market their products under the Thai government product branding of "OTOP." The brand personifies the perceived value (Mi & Baharun, 2013), and by becoming an OTOP branded product, many doors to foreign markets can open, which is currently growing at nearly 2% per year. This is also supplemented by a large domestic market which has also been growing at a constant annual rate of 13% over the past several years (Changson, 2015).

Recently, a new program called "From Hundred to Million" has also been conceived which is designed to help stimulate young entrepreneurs' creativity and innovation (National News Bureau of Thailand, 2015), which is actually mirroring one of the main objectives of Governor Hiramatsu's OVOP concept in 1979. Further incentives for entrepreneurs to join in OTOP branding of their products includes initiatives such as the OTOP Product Champion (OPC) certification that aims to improve the quality of CBE products (Natsuda et al., 2011).

Innovators are, first and foremost, entrepreneurs (The World Bank, 2010). Thailand's CBE and SME OTOP entrepreneurial enterprises represent US\$3 billion to the economy and crucial to Thailand's economic health. Various factors, however, contribute to export performance strategy and success (Hirohata, 2013). In the past, Thai entrepreneurial agricultural and handicraft exporters have experienced various challenges in overseas markets, including customer confidence, trust, and lack of product branding and identification (Piriyakul & Wingwon, 2011). Production capacity for export purposes is a great challenge for developing nations, which in turn influences the quality, service standard, and production scale (The World Bank, 2010), while customer satisfaction with goods and service acting as critical components to export performance (Julian, 2003; The World Bank, 2010). Therefore, from a national sample of 500 entrepreneurs, we set out to determine how product quality, competitiveness, distribution satisfaction, and trust affect the OTOP brand's product export performance strategy.

Literature Review

Export Performance Strategy (EPS)

A multitude of experts and studies were analyzed in the lead-up to the development of the variables for the study's hypotheses concerning Thai entrepreneurial CBE/OTOP export performance strategy. Amongst these and most frequently mentioned were the Cavusgil and Zou (CZ) (Cavusgil & Zou, 1994) and the Export Performance (EXPERF) (Zou, Taylor, & Osland, 1998) models. We, however, found the history of European SMEs as discussed by the Dutch scholar Voerman (2003) particularly interesting, as well as the detailed analysis on export performance from the Brazilian authors Carneiro, da Rocha, and da Silva (2007).

Finding agreement, however, on what components actually contribute to a firm's export performance is complex, with confirmation of this difficulty coming from early research from Aaby and Slater (1989), which conducted a review of 55 studies on the management influences on export performance from 1978 to 1988 and synthesized the findings down to

the independent variables environment, competencies, firm characteristics (i.e., firm characteristics, firm capabilities, and management characteristics), and strategy (Voerman, 2003).

Madsen (1987) also synthesized 17 export performance studies from 1964 to 1985 into 23 latent variables grouped into three categories, which were referred to as organizational performance (O-performance), the structure and performance of its environment (E-structure), and strategies (strategy). Sousa (2004) later reviewed 43 empirical studies published between 1998 and 2004, and noted 50 different operational aspects of export performance, while Leonidou (2004) on the other hand compiled data from 32 empirical studies and identified 39 barriers to export performance of small businesses.

Zou et al. (1998) are also recognized for their EXPERF model whose key dimensions for measuring export performance include financial, strategic, and satisfaction. This scale has been empirically validated in a cross-national study of US and Japanese exporters, as well as in a study of UK and Australian exporters (Styles & Ambler, 1994), and a study of British exporters, strengthening its value as a valid generalized export performance measure (Beleska-Spasova, 2014).

The literature does also suggest that export performance is closely associated with the characteristics of the enterprise, including such things as the size, the firm's age, and who the entrepreneurs are, as in this study's case (Zou et al., 1998). The research, however, did identify other studies concerning export performance which were focused on smaller SME organizations. This included Bartlett and Bukvić (2001), Leonidou (2004), Leonidou, Katsikeas, and Samieec (2002), and Styles and Ambler (1994).

Styles and Ambler (1994) revised an earlier export performance framework from Aaby and Slater (1989) and concluded that it was the partnership and relationship factors which had the greatest influence on export performance improvement. Later Styles (1998) refined Cavusgil and Zou's (1994) model for use in the analysis of SMEs in Australia and United Kingdom firms, and determined that economic performance, improvement of competitive position,

future expansion, and passive exporting were the keys to SME export performance.

Research from Bartlett and Bukvić (2001) also focused on SMEs and investigated what hindered their growth the greatest, and strongly suggested that unless flexibly and deregulation are embraced, there will be significant barriers to small business growth.

Bilkey (1978) determined that management quality is the greatest single determinant of a firm's export success. Ayan and Percin (2005) also determined that export market success depends on foreign environments, managerial characteristics, and the firm's marketing strategies. Brenčić, Ekar, and Virant (2008) defined export performance as profitability, which is reflected in sale volume, rapid growth, global competitiveness, strategic position, global market share, performance satisfaction, and success with the export venture which fully meets expectations. Export performance factors are also determined by profit, return of investment (ROI), revenue, total sales, market shares, sales growth rate, export growth rates, or the number of new customers (Abu-Jarad, Yusof, & Nikbin, 2010).

This is consistent with Ural (2009), which demonstrated that there is a positive impact from information sharing, strategic positioning, and performance on financial export performance and satisfaction with the export venture. Stuart, Verville, and Taskin (2011) examined trust between supplier and buyer firms as well as the impact that trust has on export performance outcomes which included customer satisfaction, market share, and profitability. This was similar to Agus and Hajinoor (2012) and Laosirihongthong, Teh, and Adebajo (2013) studies that emphasized the importance of market share, profitability, sales growth, and market growth on export performance.

From these and other studies concerning theories about export performance strategy, a review of the literature and theory led to the following observed variables being determined: market share (EPS1), profitability (EPS2), rapid growth (EPS3), sales volume (EPS4), strategic position growth (EPS5), satisfied performance (EPS6), and global competitiveness (EPS7).

Product Quality (PRQ)

According to an export marketing performance survey conducted on Thai SMEs, one of the four factors determined to have a significant contribution was product characteristics (Julian, 2003). The three others included competition, commitment, and the export market characteristics. Concerning product characteristics, it was stated that concentration should be focused on product flexibility, which meets the need of the market, specifically cultural specificity, and the degree of uniqueness of the product.

Bei and Chiao (2001) concluded that the most significant factor was the quality of goods. The World Bank (2010) has also indicated the importance of solid infrastructure for norms, standards, and quality control, which therefore assures the proper commercialization of products for either domestic or foreign markets. Similarly, Tsiotsou (2005) concluded competitive comparisons as a key success factor.

Other factors such as fulfilling expectations, meeting customer's goals, and having positive customer relationships are also significant (Tohidinia & Haghghi, 2011). Product performance, conformance to specifications, reliability, and durability are also applicable (Agus & Hajinoor, 2012).

Additionally, Wang and Tsai (2012) stated that outstanding quality, reliability, and consistency are crucial elements of perceived quality as well, with Laosirihongthong et al. (2013) stating that a product's performance, its conformance to specifications, reliability, and durability are equally important. Chang, Kuo, Hsu, and Cheng (2014) cited broader factors of information, service, and system quality.

From these and other studies concerning theories about product quality (PRQ), the review of the literature and theory led to the following observed variables being determined which included best quality (PRQ1), excellent standards (PRQ2), overall quality (PRQ3), and service quality (PRQ4). This then led to the conceptualization of the following three hypotheses:

H1: Product quality (PRQ) has a direct influence on trust (TR).

H2: Product quality (PRQ) has a direct influence on distribution satisfaction (DIS).

H5: Product quality (PRQ) has a direct influence on export performance strategy (EPS).

Competitiveness (COM)

In Thailand, Julian (2003) studied SME export performance and indicated that price competitiveness in the export market and product commitment as important factors in export marketing success. Leonidou et al. (2002) additionally indicated that price flexibility and the ability to offer lower prices (i.e., penetration pricing) were positive aspects for export performance. This was consistent with Bei and Chiao (2001), which also indicated the importance of a reasonable price. Rijkers (2014) also recognized the importance of price and indicated it should be competitive or equal to competitors' pricing scales as well as corresponding to market trends.

From these and other studies concerning theories about competitiveness (COM), a review of the literature and theory led to the following observed variables being determined which included Reasonable price (COM1), fair price (COM2), acceptable price (COM3), competitive market price (COM4), and market trends (COM5). This then led to the conceptualization of the following two hypotheses:

H3: Competitiveness (COM) has a direct influence on trust (TR).

H4: Competitiveness (COM) has a direct influence on distribution satisfaction (DIS).

Trust (TR)

According to Uslaner (2001), the roots and consequences of trust are precisely what we would expect of a moral value. Values should be stable over time—and not dependent upon day-to-day experiences. This is consistent with Lo (2003), which indicated that trust consists of integrity, benevolence, ability, perception, and communication. Jin, Park, and Kim (2007) highlighted trust and value in Korea as coming from a firm's reputation.

Trust however for international exporters can be difficult to achieve, as from the 15,822 respondents

of a Reader's Digest study, it was found that only 32% of consumers trusted international companies, and only 13% trusted advertising (Pumim, Srinuan, & Panjakajornsak, 2017).

In Thailand, Piriyakul and Wingwon (2011) felt consumer trust towards a product brand played a critical role in supporting sustainable corporate growth. Brenčić et al. (2008), indicated that a long-term orientation is a consequence of trust and relationship commitment, with Lin (2013) indicating that significant and positive relationships were found between trust and satisfaction, and between satisfaction and loyalty.

Furthermore, according to Moliner (2008), trust is defined as being trustworthy, honest, and having a good reputation. Stuart et al. (2011), however, see trust as being built principally through supplier centric traditional performance metrics such as delivery reliability and product quality conformance.

Trust is also earned when performance meets expectations and comes from reliable products (Valvi & West, 2013). To achieve trust, enterprises need to respond to a customer's need, have honesty and sincerity, keep commitments, and possess competency and effectiveness in their service delivery (Alsajjan, 2014). This is consistent with Chang et al. (2014), which determined that for businesses to promote trust, they must provide excellent service that is reliable and delivered with good intentions. Rijkers (2014) found that trust is earned from firms being reasonable, fair, having appropriate services, and price consistency.

From these and other studies concerning theories about trust (TR), the review of the literature and theory led to the following observed variables being determined which included being trustworthy (TR1), ability (TR2), judgement (TR3), and product trust (TR4). This then led to the conceptualization of the following two hypotheses:

H6: Trust (TR) has a direct influence on distribution capability (DIS)

H7: Trust (TR) has a direct influence on export performance strategy (EPS)

Distribution Satisfaction (DIS)

According to a research from Saudi Arabia, product and distribution capabilities were shown to have a

significant direct effect on export performance for low involvement exporters (Al-Aali, Lim, Khan, & Khurshid, 2013).

Distribution satisfaction as a core idea in global logistics importance can be expressed in the 1978 FedEx slogan “when it absolutely, positively has to be there overnight” campaign which helped FedEx separate its brand from its competition, which by the 1990s, had made the company the largest express transportation company in the world (Maital, 1995).

This is consistent with Zou and Stan (1998), which in 50 papers published between 1987 and 1997, determined that of the seven categories measuring export performance, satisfaction was a key element. Hill, Jones, and Schilling (2017) stated that identification of the customer’s needs, along with superior fulfillment of customer satisfaction over rivals, contributed to a competitive advantage.

Anderson and Fornell (2000) divided customer satisfaction into three determinants: perceived service quality, perceived value, and customer expectations. Satisfaction can also be defined broadly as a customer being satisfied with a product or service (Bei & Chiao,

2001). Additionally, Tohidinia and Haghghi (2011) indicated that relationship quality had a significant impact with customer satisfaction and that customer satisfaction had a positive impact on re-purchase intentions, positive word-of-mouth, and customer’s positive feedback, which leads to happiness and overall satisfaction (Vesel & Zabkar, 2010; Tsiotsou, 2005).

From these and other studies concerning theories about distribution capabilities (DIS), a synthesise of the research led to the following observed variables being determined which included being overall satisfaction (DIS1), product satisfaction (DIS2), exceeds expectations (DIS3), satisfied service (DIS4), purchase decision satisfaction (DIS5), and satisfied needs (DIS6). This then led to the conceptualization of this hypothesis:

H8: Distribution capabilities (DIS) has a direct influence on export performance strategy (EPS).

From the above theory and literature, both the latent and observed variables and their related hypotheses are presented in Figure 2.

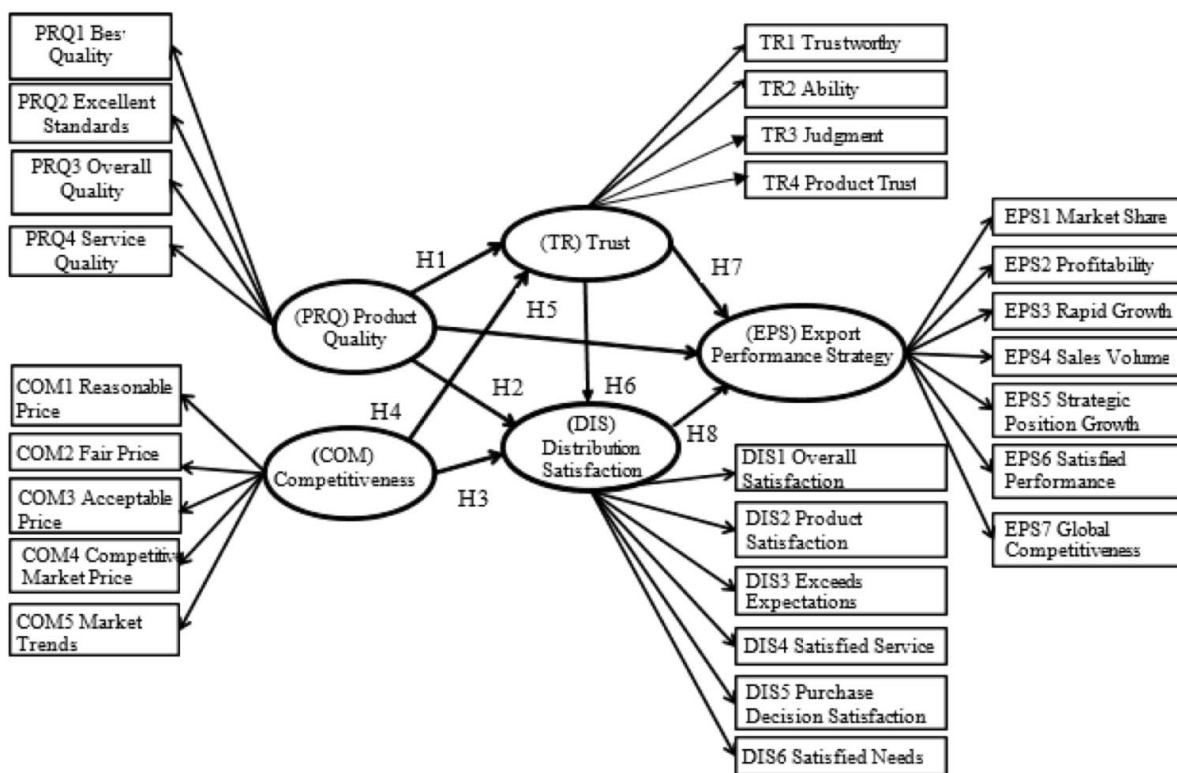

Figure 2. Hypothesized framework.

Methods

Data Collection

From the 2015 Thai Exporter Directory Database from the Ministry of Commerce's Department of International Trade (DIP), 1,353 listed Thai OTOP exporters were extracted. Starting in November 2014, phone calls were placed to 720 enterprise entrepreneurs involved in the export of Thai handicraft and food-related products. Upon contact with these owners, the best method for sending the export performance strategy questionnaire was determined (post, e-mail, courier, etc.). Subsequent follow-up calls and emails were made in December 2014 and January 2015 to those owners who had not returned the survey, with the completion of the follow-up process ending in February 2015. From this process, the targeted collection number was not achieved.

Therefore, 10 teams were selected and deployed to physically travel to the enterprises' location in May 2015 and gather a completed survey. From this added level of collection, the researchers obtained 545 questionnaires. This represented a collection rate of 75.69% (545 of the original 720 enterprises identified). Subsequent quality control and auditing of the responses eliminated 45 sets, leaving a final survey response rate of 69.44% or 500 of the originally identified 720 enterprises, exceeding statistical sampling criteria by Krejcie and Morgan (1970), Schumacker and Lomax (2004), and Yamane (1967).

Furthermore, during the period March to May 2015, qualitative research was conducted by use of in-depth, semi-structured, guided interviews with seven owners and executives covering the measurement of product quality, competitiveness, trust, distribution satisfaction, and export performance strategy.

For the study, Cronbach's alpha (Cronbach, 1951) was used to evaluate the initial 30 "try-out" samples which used a 6-point, unipolar scale survey rating matrix with "5" indicating "excellent" and "0" indicating "no opinion." The value of alpha (α) that is considered acceptable ranges in value from 0 to 1 and may be used to describe the reliability of factors extracted from multi-point formatted questionnaires or scales, with a reliability score of 0.70 or higher being considered a reliable score by many researchers

(Hair, Hult, Ringle, & Sarstedt, 2016). The correlation coefficient indicated high reliability with a score of 0.953.

Quantitative Data Analysis

To determine if the sample size of 500 exporters, selected by use of simple random sampling for the study, was adequate, we further confirmed this to be the case from previous researchers (Schumacker & Lomax, 2004; Hair et al., 2016).

The questionnaire used a 6-point unipolar scale, with 5 indicating "excellent" and 0 indicating "no quality." This was adapted from the export performance rating scale used by Pope (2002) to measure small firms.

Analysis of Thai owner and entrepreneur export performance was conducted using descriptive statistics including frequency, percentage, mean, and standard deviation (Keengwe & Onchwari, 2011).

From literature reviews and theory, the following latent and observed variables shown in Table 1 were analyzed for this study.

Confirmatory Factor Analysis (CFA)

To access the measurement models, a CFA is used followed by structural equation modeling (SEM) to examine the general fit of the proposed model. Wong (2013) also indicated that for marketing research, a significance level of 5%, a statistical power of 80%, and R^2 values of at least 0.25 are considered typical.

Standard modelling accepts the proposed model if the p-value is higher than 0.05 and if the χ^2/df ratio is smaller than two (Byrne, Shavelson, & Muthén, 1989) which is consistent with Kline (1998) which also indicated that the relative χ^2 (chi-square) should be less than two. It is also common to display confirmatory factor models as path diagrams in which squares show the observed variables and circles show the latent concepts (Albright & Park, 2009).

Additionally, another common reported statistic and a potential mechanism for accommodating large sample sizes may be to use the root mean square error of approximation (RMSEA) as a measure of goodness-of-fit in SEMs (Steiger & Lind, 1980), and to measure the discrepancy per degree of freedom (df; Hu & Bentler, 1999). Also, a value of 0.05 or less in RMSEA reporting indicates a close fit of the model

Table 1

Summary of Exogenous Latent Variables, Endogenous Latent Variables Along with Their Observed Variables and Associated Theory

Latent variables (5)	Observed variables (26)	Knowledge Base (Theory)
Exogenous		
Product Quality (PRQ)	(PRQ1) Best Quality (PRQ2) Excellent Standards (PRQ3) Overall Quality (PRQ4) Service Quality	Agus & Hajinoor, 2012; Anderson et al., 1996; (Bei & Chiao, 2001; Bilkey, 1978; Brown, 2003; Chang et al., 2014; Moliner, 2008; Julian, 2003; Laosirihongthong et al., 2013; Mi & Baharun, 2013; The World Bank, 2010; Tohidinia & Haghghi, 2011; Tsiotsou, 2005; Wang & Tsai, 2012.
Competitiveness (COM)	(COM1) Reasonable Price (COM2) Fair price (COM3) Acceptable Price (COM4) Competitive Market Price (COM5) Market Trends	Bei & Chiao, 2001; Dai, 2010; Julian, 2003; Leonidou et al., 2002; Moliner, 2008; Rijkers, 2014; Valvi & West, 2013; Wang & Tsai, 2012.
Endogenous		
Trust (TR)	(TR1) Trustworthy (TR2) Ability (TR3) Judgment (TR4) Product Trust	Alsajjan, 2014; Brenčič et al., 2008; Chang et al., 2014; Jin et al., 2007; Lin, 2013; Lo, 2003; Moliner, 2008; Piriyakul & Wingwon, 2011; Rijkers, 2014; Stuart et al., 2011; Valvi & West, 2013; Uslaner, 2001.
Distribution Satisfaction (DIS)	(DIS1) Overall Satisfaction (DIS2) Product Satisfaction (DIS3) Exceeds Expectations (DIS4) Satisfied Service (DIS5) Purchase Decision Satisfaction (DIS6) Satisfied Needs	Al-Aali et al., 2013; Anderson & Fornell, 2000; Bei & Chiao, 2001; Dai, 2010; Hill et al., 2015; Maital, 1995; Tohidinia & Haghghi, 2011; Tsiotsou, 2005; Vesel & Zabkar, 2010; Zou & Stan, 1998.
Export Performance Strategy' (EPS)	(EPS1) Market Share (EPS2) Profitability (EPS3) Rapid Growth (EPS4) Sales Volume (EPS5) Strategic Position Growth (EPS6) Satisfied Performance (EPS7) Global Competitiveness	Abu-Jarad et al., 2010; Agus & Hajinoor, 2012; Ayan & Percin, 2005; Brenčič et al., 2008; Brown, 2003; Laosirihongthong et al., 2013; Stuart et al., 2011; Ural, 2009; Yusof & Nikbin, 2010.

in relation to the degrees of freedom, with a smaller RMSEA value indicating a better model fit.

Results

Respondents Characteristics

Of the 500 respondents for the study, 301 were female (60.2%) and 199 were males (39.8%). These

respondents were divided into five age groups: 41–50 years old (156 respondents or 31.2%); 154 respondents who were 31–40 years old (30.8%); 51–62 years old (85 respondents or 17.0 %); 76 respondents who were under 30 years old (15.2%), with the remaining group over 60 years old of age with 29 respondents (5.8%).

Regarding education, 220 of the 500 surveyed respondents had Bachelor's Degrees (44.0%), the

second largest group with 141 respondents had vocational education (28.2%), with the remaining respondents represented by other types of education including 15 with Master’s Degrees (3.0%), with the remaining 124 respondents representing other or lower educational levels (24.8%).

Among the total 500 respondents, 440 respondents were business owners, representing 88% of the total, with the remainder 60 (12.0%) indicating “business executives” as their title/position. Work experience was broken down into those with 10 or more years’ experience (231 or 46.2%), those with 6–10 years of work experience (124 or 24.8 %), those with one to five years of experience (120 or 24.0%) and finally, the smallest group was those with less than one year of experiences (25 respondents or 5.0%).

The vast majority of the entrepreneurs surveyed either owned or worked in groups that had 50 or fewer employees representing 472 of the respondents (94.4%). This was followed by 22 respondents (4.4%) working in groups with 51–100 employees, with only two of the total of 500 surveyed working in organizations larger than 101 employees (0.4%).

Additionally, the respondents are divided into 10 groups according to their assets. The largest group

was represented by those with maximum assets not exceeding five million THB (US\$144,000) which had 216 members (43.2%). This was followed by 76 exporters (15.2%) with assets between 26–50 million THB. Another group with 56 respondents (11.2%) had assets between 51–75 million THB, followed by 53 respondents between 6–25 million THB (10.6%). Respondents with assets between 76-100 million THB included 42 respondents (8.4%); between 101–125 million THB, 21 respondents (4.2%); between 126–150 million THB, 20 respondents (4.0%); between 151–175 million THB, nine respondents (1.8%); between 176–200 million THB, six respondents (1.2%); and finally, the last group with assets over 200 million THB was just one respondent (0.2%).

CFA Results

From the CFA analysis, RMSEA was determined to be < .05 (Figure 3 and Figure 4). Additionally, other goodness of fit statistics (GOF) indicated the following: χ^2 was statistically insignificant ($p > .05$), $\chi^2 / df < 2.00$, goodness-of-fit index - GFI > .90, adjusted goodness of fir index - AGFI > .90, and the standardized root mean square residual - SRMR < .05.

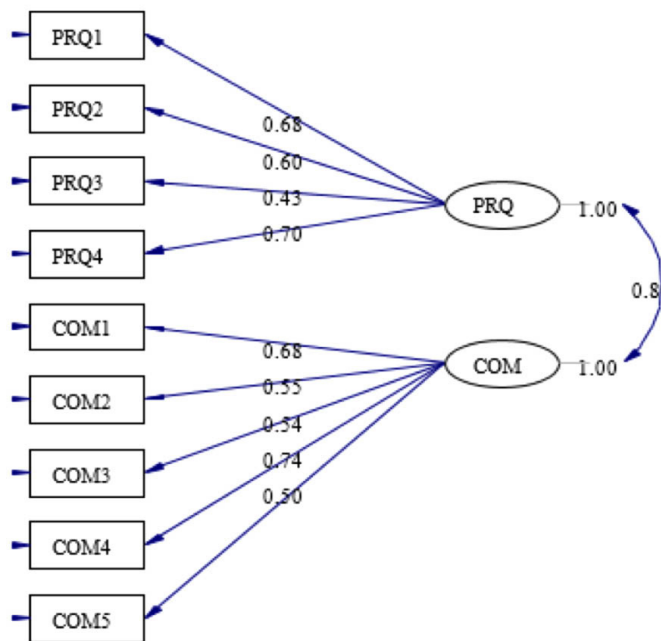

Figure 3. CFA for the exogenous latent variables.

Note. Chi-Square=4.83, df=11, p-value=0.94, RMSEA=0.000.

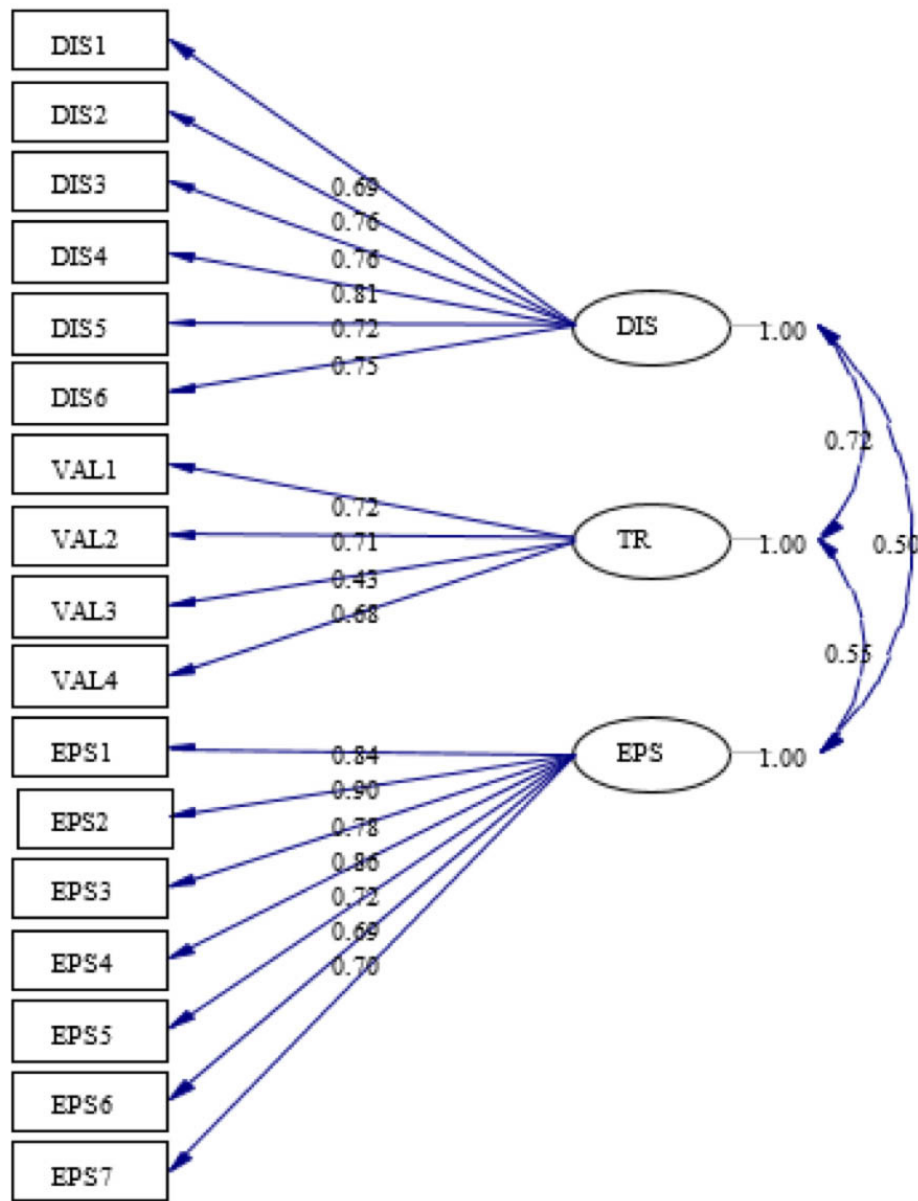

Figure 4. CFA for the endogenous latent variables.

Note: Chi-Square=32.69, df=45, P-value=0.91, RMSEA=0.000.

Construct Validity

Overall validity was determined by testing both convergent and discriminant validity in combination. Convergent validity uses three tests including item reliability, composite reliability (CR), and average variance extracted (AVE; Chau, 1997; see Table 2). Furthermore, item reliability is confirmed if factor

loadings are 0.50 or above, while CR is assessed based on the criteria that the indicator’s estimated pattern coefficient is significant on its underlying factor, which should have a threshold value for construct reliability at 0.70 or higher. Table 2 shows that the CR was higher than 0.60, with all AVE values higher than 0.50, and all R² values classified as “substantial” (Hair et al., 2016).

Structural Equation Modeling Results

In structural equation modeling, the fit indices establish whether, overall, the model is acceptable. The fit indices can be classified into several classes, with researchers such as Marsh, Hau, and Wen (2004) and Jaccard and Wan (1996) recommending researchers to use a range of fit indices. This strategy overcomes the limitations of each index, with scholars in Table 3 regarding a model acceptable if certain criteria have been established and met.

Additionally, Hooper, Coughlan, and Mullen (2008) indicated that items with low multiple R^2 (less than 0.20) should be removed from an analysis as this is an indication of very high levels of error. Hair et al. (2016) also confirmed this and stated that R^2 values should be higher than 0.25.

From Table 3, GFI is indicated to be 0.96 which is the goodness-of-fit statistic (GFI). Traditionally an omnibus cut-off of 0.90 has been recommended for the GFI (Hooper et al., 2008). Values for the AGFI

Table 2

Correlation Coefficients Between Latent Variables (Under the Diagonal), the Latency of the Latent Variable (ρ_c), and the Average Variance Extracted (AVE)

Latent Variables	PRO	COM	VAL	DIS	EPS
Product Quality (PRQ)	1.00				
Competitiveness (COM)	0.543	1.00			
Trust (TR)	0.415	0.563	1.00		
Distribution Satisfaction (DIS)	0.410	0.673	0.635	1.00	
Export Performance Strategy (EPS)	0.396	0.473	0.443	0.437	1.00
ρ_c (Construct Reliability)	0.780	0.763	0.806	0.881	0.924
ρ_v (AVE)	0.470	0.395	0.511	0.554	0.636
\sqrt{AVE}	0.686	0.629	0.715	0.744	0.798

Note. Statistical significance level is at the 0.01 level and the numbers in the bolded diagonal figures indicates \sqrt{AVE} , AVE = average variance extracted.

Table 3

Criteria and Theory of the Values of Goodness-of-Fit Appraisal

Criteria Index	Criteria	Values	Results	Supporting theory
Chi-square: χ^2 p value must be higher than 0.05, with higher better	($p > 0.05$)	0.091	passed	(Rasch, 1980)
Relative Chi-square χ^2/df	≤ 2.00	1.285	passed	(Byrne et al., 1989)
GFI	≥ 0.90	0.98	passed	(Hair et al., 2016)
AGFI	≥ 0.90	0.96	passed	(Hooper et al., 2008)
RMSEA	≤ 0.06	0.000	passed	(Hu & Bentler, 1999; Steiger & Lind, 1980)
Standardized Root Mean Square	≤ 0.08	0.02	passed	(Hu & Bentler, 1999)
Residual (SRMR)				
Cronbach's Alpha	≥ 0.70	0.93	passed	(Hair et al., 2016; Cronbach, 1951)

also ranged between zero and one, and it is generally accepted that values of 0.90 or greater indicate well-fitting models (Hooper et al., 2008). The adjusted goodness-of-fit statistic (AGFI) for the study is 0.96.

Rasch (1980) evaluated χ^2 statistics as a way of evaluating the fit of data to the model and indicated that a sample size of 500 has a five percent range of 0.91–1.09. The χ^2 value of 302.04 for the 109 degrees of freedom (df) is insignificant. Thus, it could say the

null hypothesis that the model presented in the paper is a good fit with the data. The error statistics of root mean square error of approximation (RMSEA) of 0.000 confirm that the errors of fit in the covariance matrix are very low. Additionally, empirical variables enable to explain variances of observed variables ensuring suitability for structural equation modeling (SEM; Figure 5).

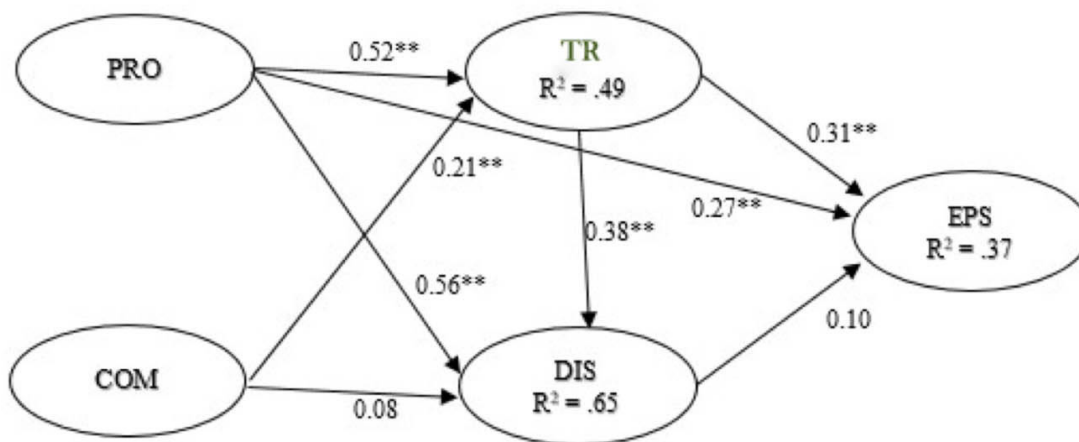

Figure 5. Relationships of the Latent Variables.

Note. ** $p < .01$, Chi-Square=110.40, $df=132$, $p\text{-value}=0.91431$, RMSEA=0.000.

Table 4

Standard Coefficients of Influence on Export Performance Strategy ($n = 500$)

Dependent variables	Effects	R ²	Independent Variables			
			PRQ	COM	TR	DIS
Export Strategy	DE		0.27*	0.00	0.31*	0.10
Performance	IE	0.37	0.23*	0.07	0.04	0.00
(EPS)	TE		0.50*	0.07	0.35*	0.10
Trust	DE		0.52*	0.21*	-	-
(TR)	IE	0.49	0.00	0.00	-	-
	TE		0.52*	0.21*	-	-
Distribution	DE		0.56*	0.08	-	-
Satisfaction	IE	0.65	0.20*	0.08	-	-
(DIS)	TE		0.76*	-0.01	-	-

Note. * = $p < .01$, TE = Total Effect, IE = Indirect Effect, DE = Direct Effect, values are estimated.

Hypothesis Testing

The results of the hypotheses testing are indicated in Figure 6 and Table 5.

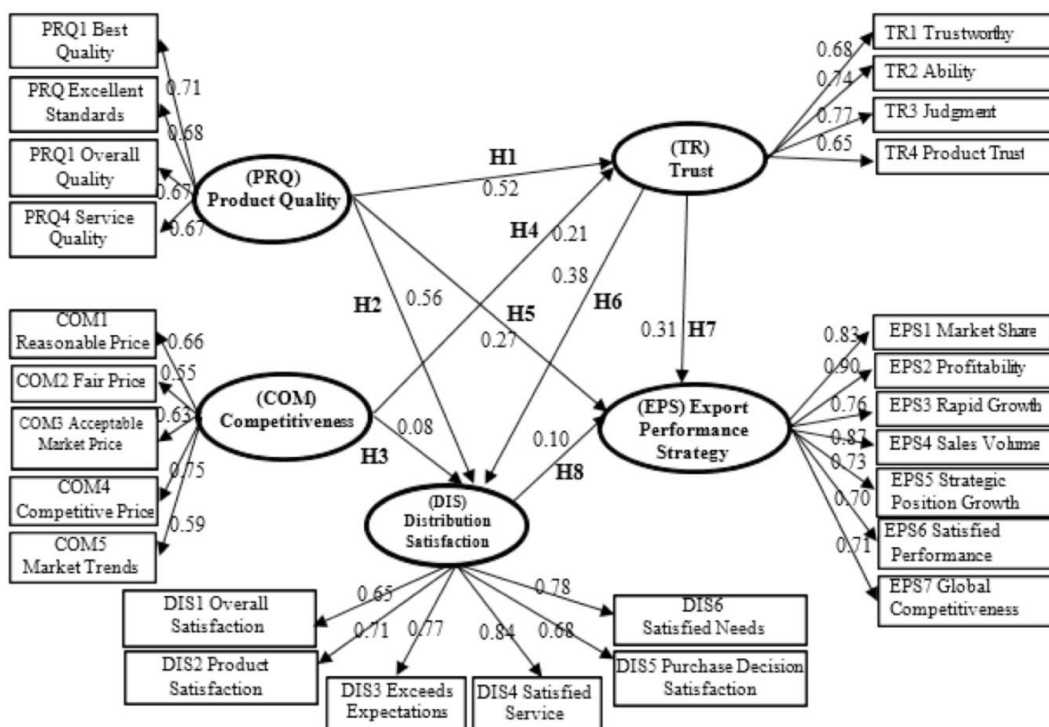

Figure 6. Final model.

Note. Chi-Square = 110.40, df = 132, p-value = 0.91431, RMSEA=0.000.

Table 5
Hypotheses Testing Results

Hypotheses	Coef.	t-value	Results
H1: Product quality (PRQ) has a direct influence on trust (TR)	0.52	5.29*	Supported
H2: Product quality (PRQ) has a direct influence on distribution satisfaction (DIS)	0.56	5.71*	Supported
H3: Competitiveness (COM) has a direct influence on trust (TR)	0.21	2.31*	Supported
H4: Competitiveness (COM) has a direct influence on distribution satisfaction (DIS)	0.08	1.06	Rejected
H5: Product quality (PRQ) has a direct influence on export performance strategy (EPS)	0.27	3.24*	Supported
H6: Trust (TR) has a direct influence on distribution satisfaction (DIS)	0.38	5.32*	Supported
H7: Trust (TR) has a direct influence on export performance strategy (EPS)	0.31	3.59*	Supported
H8: Distribution satisfaction (DIS) has a direct influence on export performance strategy (EPS)	0.10	1.16	Rejected

Note. *Sig. < 0.01.

Discussion

From the research concerning Thai entrepreneurial OTOP export performance strategy, product quality (PRQ) was determined to play a key role and supported three of the study's eight hypotheses (H1, H2, and H3). In H1, product quality (PRQ) was found to have a significant role in the export customer's trust, which is consistent with numerous studies (Piriyakul & Wingwon, 2011). The medium in which the message is communicated also plays a significant role as to how the message is trusted (Pumim et al., 2017). An excellent example of this is the use of events, complimentary sampling, and social media such as Facebook, in establishing customer trust for a Myanmar organic coffee company (Consult-Myanmar, 2017).

Also, Thai OTOP product exporters need to support product quality that meets standards for both the domestic and international markets (Natsuda et al., 2011), while also meeting production standards that are suitable for customer needs, including durability and good customer service. These factors have a significant influence on a customer's trust.

In H2, product quality (PRQ) was also determined to have a positive impact on distribution satisfaction (DIS), which requires products to be durable and maintained through an excellent product service system. This is consistent with the European Consumer Organization (BEUC, 2015), which has stated that reliable and durable products provide value for money to consumers and prevent overuse of resources and waste.

Product quality (PRQ) was also hypothesized to affect export performance strategy (H5), which was confirmed and consistent with Leonidou et al. (2002) and Prayukvong (2007). However, in a United States Agency for International Development (2005) study of Thai OTOP village cluster competitiveness, it was stated that the villages were in dire need of basic management training, product standardization, maintaining uniform output, understanding costs, and cash flows. This is consistent with Lakanapipat, Smith, and Tubsree (2016), which indicated that leadership is a vital factor for the success of the local OTOP schemes.

Concerning the hypothesized relationships of (H3), competitiveness (COM) to trust (TR), and (H4) competitiveness (COM) to distribution satisfaction (DIS), results were mixed, with H3 supported and H4 rejected. Research from Ismail (2011) has also given support to H3, as it was determined that trust is important in developing and maintaining productive cross-border business relationships, and, thus, a firm's competitiveness. Other research confirming this include Moliner (2008), Valvi and West (2013), and Wang and Tsai (2012).

However, H4 was rejected and determined to not have a significant influence on an OTOP entrepreneur's export performance distribution satisfaction (DIS). Speculation for this most probably comes from OTOP product pricing for export being "standardized" by various organizations involved in the process. This comes from the "top-down" style of Thai business culture, and the OTOP program in Thailand. This top-down price control, however, has also been stated to be a fundamental flaw within the OTOP program's export performance success in Thailand in the past. According to Liu and Li (2017), giving industry owners and managers the rights to set prices encourages villagers to develop their skills, as well as adding flexibility and competitiveness in following market changes and consumer preferences.

Concerning H6's relationship of trust (TR) on distribution satisfaction (DIS) and H7's relationship of trust (TR) on export performance strategy (EPS), both were supported. Once again, according to the United States Agency for International Development (2005), establishing direct relationships with customers exposes members to overseas buyers' preferences and trends, and facilitates the establishment of long-term relationships based on trust and customer service. Trust (TR) also directly influences export performance strategy (EPS), which is supported by past Thai entrepreneurial studies that said agricultural and handicraft exporters have experienced various challenges in overseas markets in the past, including customer confidence, trust, and lack of product branding and identification (Piriyakul & Wingwon, 2011).

Lastly, H8's hypothesized relationship of distribution satisfaction (DIS) to export performance strategy (EPS)

was rejected. Reasons for this most probably are based on the processes of distribution and export for OTOP products in Thailand, which in many cases are government controlled, such as with shops at airports, in-flight catalogs, national gas stations shops, and so forth. However, if product orders come from online OTOP portals, it is imperative that communications are established with the customers which are maintained through order completion. SMEs must fulfill their orders and deliver their products to worldwide buyers promptly, and be aware of local regulatory issues which can delay or lead to the cancellation of an order (Phetcharat, 2017).

Conclusion

The study explored community-based enterprise export operations by OTOP in Thailand. A study of the literature revealed that there were four main elements in a product's export performance strategy. These included the product's quality, the product's competitiveness, the customer's trust, and finally, the satisfaction related to how the distribution process was enabled. From both this study and similar research, production capacity for export purposes is a great challenge for developing nations. This, in turn, affects the quality, service standard, and production scale capabilities of the vendors. Also, customer satisfaction with goods and service act as critical components to export performance. Efforts must be made to embrace communications technologies, such as social media, to help with the process at every step of the way. Scientific methods and technologies are needed to suggest the best strategies for improving rural conditions, with digital innovation (smartphones, Internet, product portals, etc.) used to improve export performance strategy. Product branding is also something else that must be firmly established, along with the associated customer trust and reliability that the branding entails.

The study also revealed that top-down policies often fail, with government-led initiatives not fully considering the peculiarities of each rural community (Liu & Li, 2017). If people's voices are not heard, they will not cooperate, with engaging locals the key to success. Organizational achievement is based on effective leadership as a core value, with "bottom-up"

initiatives acting as "social glue," encouraging people to work together; as compared to top-down, which disengages communities.

Implications and Suggestions

1. Thailand's total e-commerce market size in 2017 will be worth US\$75.5 billion, a 12.4% growth from 2016 (Phetcharat, 2017). Still, more than 80% of Thailand's e-commerce market growth comes from domestic trade, leaving room to boost the country's economic growth by internationalizing small and medium enterprises (SMEs). Thailand's OTOP program is a front-runner for this.
2. The Thai government's Industry 4.0 policy aims to "digitize" to allow it to better compete on a global level, and SMEs are at the forefront of this transformation (Jones & Pimdee, 2017). Digitalization will reduce the need for paperwork, creating a smoother and quicker access to information.
3. Thai SMEs should gain both reach and experience in selling online. They should also take advantage of emerging government funds for digital technology adoption and up-skilling of their workers.
4. Export sector success depends on properly designed production plan to meet the needs and growth of customers which assures the exporters' strategic strength.
5. To achieve this goal, marketable products with clear and proper positioning must be realized. Product branding is also crucial to success.
6. Due to the rapid development of the global economy, many companies choose diversification as their strategic choice (Song & Wang, 2011).
7. Trust must be maintained between the customer and the exporter, as well as on customer's trust in the deliverables, the contracts, the scheduling, and the production quotas.
8. Competitiveness must follow market trends, and be reasonable and acceptable. As such, the exporter should monitor their customer's satisfaction level periodically.

References

- Aaby, N. E., & Slater, S. F. (1989). Management influences on export performance: A review of the empirical literature 1978–88. *International Marketing Review*, 6(4), 7–25. doi:10.1108/EUM000000001516
- Abu-Jarad, I. Y., Yusof, N. A., & Nikbin, D. (2010). A review paper on organizational culture and organizational performance. *International Journal of Business and Social Science*, 1(3), 26–46. Retrieved from <http://tinyurl.com/hpgk2ro>
- Agus, A., & Hajinoor, M. S. (2012). Lean production supply chain management as driver towards enhancing product quality and business performance: Case study of manufacturing companies in Malaysia. *International Journal of Quality & Reliability Management*, 29(1), 92–121. doi:10.1108/02656711211190891
- Al-Aali, A., Lim, J.-S., Khan, T., & Khurshid, M. (2013). Marketing capability and export performance: The moderating effect of export performance. *South African Journal of Business Management*, 44(3), 59–70. Retrieved from <http://tinyurl.com/y6tsjw>
- Albright, J. J., & Park, H. M. (2009). Confirmatory factor analysis using Amos, LISREL, Mplus, SAS/STAT CALIS*. Retrieved from <http://tinyurl.com/hp6xmhk>
- Alsajjan, B. A. (2014). Satisfaction-trust model: Developing customer satisfaction and trust indices for mobile service providers in the UK. *International Review of Management and Business Research*, 3(2), 1088–1104. Retrieved from <http://tinyurl.com/jtya9eh>
- Anderson, E. W., & Fornell, C. (2000). Foundations of the American customer satisfaction index. *Total Quality Management*, 11(7), 869–882. doi:10.1080/09544120050135425
- Anh, N. T. (2013). One Village One Product (OVOP) in Japan to One Tambon One Product (OTOP) in Thailand: Lessons for grass root development in developing countries. *Journal of Social and Development Sciences*, 4(12), 529–537. Retrieved from <http://tinyurl.com/y8wuqv3d>
- Asia-Pacific Economic Cooperation. (2003). Joint Ministerial Statement: Strengthening an APEC entrepreneurial society. APEC small and medium enterprise ministerial meeting Held in Chiang Mai, Thailand, on August 7–8. Retrieved from <http://tinyurl.com/hrmbulb>
- Ayan, T. Y., & Percin, S. (2005). A structural analysis of the determinants of export performance: Evidence from Turkey. *Innovative Marketing*, 1(2), 106–120. Retrieved from <http://tinyurl.com/z589ofk>
- Bartlett, W. J., & Bukvić, V. (2001). Barriers to SME growth in Slovenia. *MOCT-MOST: Economic Policy in Transitional Economies*, 11, 17–195. doi:10.1023/A:1012206414785
- Bei, L. T., & Chiao, C. Y. (2001). An integrated model for the effects of perceived product, perceived service quality, and perceived price fairness on consumer satisfaction and loyalty. *Journal of Consumer Satisfaction, Dissatisfaction and Complaining Behavior*, 14, 125–140. Retrieved from <http://tinyurl.com/h43zkno>
- Beleska-Spasova, E. (2014). Determinants and measure of export performance – comprehensive literature review. *Journal of Contemporary and Business Issues*, 1(1), 63–74. Retrieved from <http://tinyurl.com/gqjsvmt>
- BEUC. (2015). Durable goods: More sustainable products, better consumer rights. Retrieved from <http://tinyurl.com/y6wod9j8>
- Bilkey, W. J. (1978). An attempted integration of the literature on the export behavior of firms. *Journal of International Business Studies*, 9, 33–46. Retrieved from <http://tinyurl.com/hcd657f>
- Brenčič, M. M., Ekar, A., & Virant, E. (2008). The influence of relationship marketing components on export performance: A comparison of transitional vs. established markets. *Original Scientific Papers*, 9–18. Retrieved from <http://tinyurl.com/zu5eb9c>
- Brown, G. K. (2003). The impact of market orientation and its strategic antecedents on business performance: Replication, corroboration, and extension of recent structural equation results (Unpublished doctoral thesis). Thammasat University, Bangkok, Thailand. Retrieved from <http://tinyurl.com/z28zhr9>
- Byrne, B. M., Shavelson, R. J., & Muthén, B. (1989). Testing for the equivalence of factor covariance and mean structures: The issue of partial measurement invariance. *Psychological Bulletin*, 105, 456–466. Retrieved from <http://tinyurl.com/jjxcxb6>
- Cagalitan, H. (2017, July 12). DTI hopes ‘one town one product’ reboot will bolster local economy even. *Panay News*. Retrieved from <http://tinyurl.com/y7fr2udh>
- Carneiro, J., da Rocha, A., & da Silva, J. F. (2007). A critical analysis of measurement models of export performance. *BAR - Brazilian Administration Review*, 4(2), 1–19. doi:10.1590/S1807-76922007000200002
- Cavusgil, S. T., & Zou, S. (1994). Marketing strategy-performance relationship: An investigation of the empirical link in export market ventures. *Journal of Marketing*, 58(1), 1–21.
- Chang, K. C., Kuo, N. T., Hsu, C. L., & Cheng, Y. S. (2014). The impact of website quality and perceived trust on customer purchase intention in the hotel sector: Website brand and perceived value as moderators. *International Journal of Innovation, Management and Technology*, 5(4), 255–260. Retrieved from <http://tinyurl.com/hfov8g>
- Changorn, P. (2015, March 28). 3 categories seen as rising stars for Otop exports. *The Nation*. Retrieved from <http://tinyurl.com/zmwmfww>

- Chau, P. Y. K. (1997). Reexamining a model for evaluating information center success using a structural equation modeling approach. *Decision Sciences*, 28(2), 309–334. doi: 10.1111/j.1540-5915.1997.tb01313.x
- Consult-Myanmar. (2017, August 9). How genius coffee cracked Myanmar's premium export market. Retrieved from <http://tinyurl.com/y6vtr882>
- Cronbach, L. J. (1951). Coefficient alpha and the international structure of tests. *Psychometric*, 16(3), 297–334. Retrieved from <http://tinyurl.com/gtfuvqg>
- Fauji, F., & Utami, M. M. (2013). How intellectual stimulation effects knowledge sharing, innovation and firm performance. *International Journal of Social Science and Humanity*, 3(4), 420–425. doi: 10.7763/ijssh.2013.v3.274
- Hair, J. F., Hult, G. T. M., Ringle, C., & Sarstedt, M. (2016). A primer on partial least squares structural equation modeling (PLS-SEM). Thousand Oaks, CA: Sage.
- Haraguchi, N. (2008). The one-village-one-product (OVOP) movement: What it is, how it has been replicated, and recommendations for a UNIDO OVOP-type project. *United Nations Industrial Development Organization (UNIDO)*. Retrieved from <https://tinyurl.com/y9w5fhba>
- Hill, C. W. L., Jones, G. R., & Schilling, M. A. (2017). *Strategic management: Theory: An integrated approach* (12th ed.). Singapore: Cengage Learning.
- Hirohata, N. (2013). One Village One Product movement in Laos. *International Journal of Engineering Innovation and Management*, 3, 31–35. Retrieved from <http://tinyurl.com/zfac866>
- Hooper, D., Coughlan, J., & Mullen, M. (2008). Structural equation modelling: Guidelines for determining model fit. *Electronic Journal of Business Research Methods*, 6(1), 53–60. Retrieved from <http://tinyurl.com/zyd6od2>
- Hörstemeier, A. (2017, September 1). How many tambon are there in Thailand? [Blog post]. Retrieved from <http://tinyurl.com/ydeqoj69>
- Hu, L. T., & Bentler, P. M. (1999). Cutoff criteria for fit indexes in covariance structure analysis: Conventional criteria versus new alternatives. *Structural Equation Modeling*, 6(1), 1–55. doi: 10.1080/10705519909540118
- Ismail, M. D. (2011, December). Role of trust in SMEs export performance. Paper presented at the International Conference on Management, Economics and Social Sciences (ICMESS'2011), Bangkok, Thailand. Retrieved from <http://tinyurl.com/ycvohnbp>
- Jaccard, J., & Wan, C. K. (1996). *LISREL approaches to interaction effects in multiple regression*. Thousand Oaks, CA: Sage Publications.
- Jin, B., Park, J. Y., & Kim, J. (2007). Cross-cultural examination of the relationships among firm reputation, e-satisfaction, e-trust, and e-loyalty. *International Marketing Review*, 25(3), 324–337. doi: 10.1108/02651330810877243
- Jones, C. & Pimdee, P. (2017). Innovative ideas: Thailand 4.0 and the fourth industrial revolution. *Asian International Journal of Social Sciences*, 17(1), 4–35. doi: 10.29139/aijss.20170101
- Julian, C. C. (2003). Export marketing performance: A study of Thailand firms. *Journal of Small Business Management*, 41(2), 213–221. doi: 10.1111/1540-627X.00077
- Keengwe, J., & Onchwari, G. (2011). Computer technology integration and student learning: Barriers and promise. *Journal of Science Education and Technology*, 17, 560–570. doi: 10.1007/s10956-008-9123-5
- Kline, R. B. (1998). *Principles and practice of structural equation modeling*. New York, NY: Guilford Press.
- Kositchothethana, B. (2017, February 20). Budget carriers' passenger traffic continues to soar. *Bangkok Post*. Accessed from <http://tinyurl.com/len4qpe>
- Krejcie, R. V., & Morgan, D. W. (1970). Determining sample size for research activities. *Educational and Psychological Measurement*, 30, 607–610. Retrieved from <http://tinyurl.com/zpzqmo6>
- Lai, P. T. (2017, July 18). Introducing SMEs to “Industry 4.0”. *Vietnamnet*. Retrieved from <http://tinyurl.com/ycnbxw9o>
- Lakhanapipat, C., Smith, I., & Tubsree, C. (2016). Leadership development in the One Tambon One Product (OTOP) scheme in Thailand. *HRD Journal*, 7(1), 36–46. Retrieved from <http://tinyurl.com/ybscsudl>
- Laosirihongthong, T., Teh, P.-L., & Adebajo, D. (2013). Revisiting quality management and performance. *Industrial Management & Data Systems*, 113(7), 990–1006. doi: 10.1108/IMDS-02-2013-0058
- Li, Y., Westlund, H., Zheng, X., & Liu, Y. J. (2016). Bottom-up initiatives and revival in the face of rural decline: Case studies from China and Sweden. *Rural Studies*, 47(Part B), 506–513.
- Lin, P.-H. (2013). Shopping motivations on the internet: An empirical study of trust, satisfaction and loyalty. *International Journal of Electronic Business Management*, 11(4), 238–246. Retrieved from <http://tinyurl.com/h2okcao>
- Liu, Y., & Li, Y. (2017). Revitalize the world's countryside. *Nature*, 548, 275–277. doi: 10.1038/548275a
- Leonidou, L. C., Katsikeas, C. S., & Samieec, S. (2002). Marketing strategy determinants of export performance: A meta-analysis. *Journal of Business Research*, 55, 51–67. doi: 10.1016/S0148-2963(00)00133-8
- Leonidou, L. C. (2004). An analysis of the barriers hindering small business export development. *Journal of Small Business Management*, 42(3), 279–302. doi: 10.1111/j.1540-627X.2004.00112.x
- Lo, C. Y. (2003). E-Business marketing on relationship management models an empirical study in Taiwan (China) [Unpublished doctoral thesis]. University of

- Hong Kong, Hong Kong, PRC. Retrieved from <http://tinyurl.com/j24tkk5>
- Madsen, T. (1987). Empirical export performance studies: A review of conceptualizations and findings. In S. T. Cavusgil (Ed.), *Advances in international marketing* (vol. 2, pp. 177–198). Greenwich, CT: JAI Press Inc.
- Maital, S. (1995). When you absolutely, positively have to give better service. In C. E. Schneier, D. G. Shaw, R. W. Beatty, & L. S. Baird (Eds.), *Performance measurement, management, and appraisal sourcebook* (pp. 247–249). Amherst, MA: Human Resource Development Press.
- Marsh, H. W., Hau, K. -T., & Wen, Z. (2004). In search of golden rules. *Structural Equation Modeling*, 11(3), 320–341.
- Mi, T. J., & Baharun, R. (2013). Introduction to SMEs in Malaysia: Growth potential and branding strategy. *World Journal of Social Sciences*, 3(6), 189–203. Retrieved from <https://tinyurl.com/y99uah9f>
- Moha-Asri, A. (2002). The impact of the Asian financial crisis on small and medium enterprises in Malaysia: Policy responses. *Journal of Comparative Asian Development*, 1(2), 227–244. doi: 10.1080/15339114.2002.9678361
- Moliner, M. A. (2008). Loyalty, perceived value and relationship quality in healthcare services. *Journal of Service Management*, 20(1), 76–97. doi: 10.1108/09564230910936869
- National News Bureau of Thailand. (2015, June 5). ‘Know global-build local’ fair helps Thai OTOP entrepreneurs reach the global market. Retrieved from <http://tinyurl.com/hvw6rf3>
- National News Bureau of Thailand. (2016, May 15). Government cooperates with Thai Airways to sell OTOP products. Retrieved from <http://tinyurl.com/jypj5qc>
- Natsuda, K., Wiboonpongse, A., Cheamuangphan, A., Shingkarat, S., & Thoburn, J. (2011). One village one product – rural development strategy in Asia: The case of OTOP in Thailand (RCAPS Working Paper No. 11). Retrieved from <http://tinyurl.com/z5kevlw>
- Phetcharat, C. (2017, August 15). Thai SMEs need to grow beyond Kingdom’s borders. *Bangkok Post*. Retrieved from <http://tinyurl.com/ycpyvama>
- Piriyakul, M., & Wingwon, B. (2011). Societal activity of corporate social responsibility as a moderating factor of brand loyalty in the ceramic industry. *Contemporary Marketing Review*, 1(3), 12–25. Retrieved from <http://tinyurl.com/hxcngta>
- Pope, R. A. (2002). Why small firms export: Another look. *Journal of Small Business Management*, 40(1), 17–26. doi: 10.1111/1540-627X.00035
- Poungsuk, P., Pourpan, N., & Thongsuk, P. (2016). Using the philosophy of sufficiency economy (PSE) in high school agricultural teaching in Northeastern (Isan) Thailand. *Asian International Journal of Social Sciences*, 16(1), 116–127. doi: 10.29139/aijss.20160106
- Prayukvong, W. (2007). A Buddhist economic approach to happiness & capability linkage in OTOP craftsmen in Southern Thailand. *Kasetsart Journal: Social Science*, 28, 161–176. Retrieved from <http://tinyurl.com/z4y4rjq>
- Pumim, A., Srinuan, C., & Panjakajornsak, V. (2017). Mobile phone customer loyalty in Thailand: A path analysis case study. *Asia-Pacific Social Science Review*, 16(3), 65–82. Retrieved from <http://tinyurl.com/ydx9qhmo>
- Rasch, G. (1980). Probabilistic models for some intelligence and attainment tests. Chicago, IL: University of Chicago Press.
- Rijkers, R. J. D. (2014). The influence of company image, trust and price on satisfaction and intensity of repurchase at the large retail businesses in Makassar, South Sulawesi Indonesia. *International Journal of Business and Behavioral Sciences*, 4(12), 1–17. Retrieved from <http://tinyurl.com/jdtg9xd>
- Schumacker, R. E., & Lomax, R. G. (2004). A beginner’s guide to structural equation modeling. Mahwah, NJ: Lawrence Erlbaum Associates. Retrieved from <http://tinyurl.com/z2sdwtr>
- Song, H. X., & Wang, F. S. (2011, August). Research on the relationship between corporate governance structure and diversification strategy. Paper presented at the International Conference on Management and Service Science (MASS), Wuhan, China. doi: 10.1109/icmss.2011.5998565
- Sousa, C. M. P. (2004). Export performance measurement: An evaluation of the empirical research in the literature. *Academy of Marketing Science Review*, 8(9), 1–22.
- Steiger, J. H., & Lind, J. (1980). Statistically-based tests for the number of common factors. Paper presented at the Annual Spring Meeting of the Psychometric Society, Iowa City, IA. Retrieved from <http://tinyurl.com/huxwndx>
- Stuart, F. L., Verville, J., & Taskin, N. (2011). Trust in buyer-supplier relationships: Supplier competency, interpersonal relationships and performance outcomes. *Journal of Enterprise Information Management*, 25(4), 392–412. doi: 10.1108/17410391211245856
- Styles, C., & Ambler, T. (1994). Successful export practice: The UK experience. *International Marketing Review*, 11(6), 23–47. doi: 10.1108/02651339410072999
- Styles, C. (1998). Export performance measures in Australia and in the United Kingdom. *Journal of International Marketing*, 6(3), 12–36. Retrieved from <http://www.jstor.org/stable/25048738>
- Suindramedhi, S. (2016). The development of community enterprise: A case study of Moku Moku Farm in Mie Prefecture. *Rangsit Journal of Social Science and Humanities*, 3(1), 33–48. Retrieved from <http://tinyurl.com/jzhzmhs>

- The World Bank. (2010). *Innovation policy: A guide for developing countries*. Washington, DC: World Bank Group. Retrieved from <http://tinyurl.com/hm84tt6>
- Tohidinia, Z., & Haghghi, M. (2011). Predictors and outcomes of relationship quality: A guide for customer-oriented strategies. *Business Strategy Series, 12*(5), 242–256. doi: 10.1108/17515631111166889
- Tsiotsou, R. (2005). The role of perceived product quality and overall satisfaction on purchase intentions. *International Journal of Consumer Studies, 30*(2), 207–217. Retrieved from <http://tinyurl.com/jfl8t6y>
- United States Agency for International Development. (2005). Thailand competitiveness initiative: Accelerating economic recovery in Asia. Retrieved from <http://tinyurl.com/yapybzew>
- Ural, T. (2009). The effects of relationship quality on export performance. *European Journal of Marketing, 43*(1/2), 139–168. doi: 10.1108/03090560910923274
- Uslaner, E. M. (2001). Trust as a moral value. Paper presented at Social Capital: Interdisciplinary Perspectives held on September 15–21 at University of Exeter, United Kingdom. Retrieved from <http://tinyurl.com/y77z4fq2>
- Valvi, A. C., & West, D. C. (2013). E-loyalty is not all about trust, price also matters: Extending expectation-confirmation theory in bookselling websites. *Journal of Electronic Commerce Research, 14*(1), 99–123. Retrieved from <http://tinyurl.com/hovdxth>
- Vesel, P., & Zabkar, V. (2010). Comprehension of relationship quality in the retail environment. *Managing Service Quality, 20*(3), 213–235. doi: 10.1108/09604521011041952
- Voerman, L. (2003). *The export performance of European SMEs*. Alblasterdam, The Netherlands: Labyrinth Publication. Retrieved from <http://tinyurl.com/jrk8cun>
- Wang, E. S-T., & Tsai, B-K. (2012). Consumer response to retail performance of organic food retailers. *British Food Journal, 116*(2), 212–227. doi: 10.1108/BFJ-05-2012-0123
- Wong, K. K.-K. (2013). Partial least squares structural equation modeling (PLS-SEM) techniques using SmartPLS. *Marketing Bulletin, 24*. Retrieved from <http://tinyurl.com/j2qjdyr>
- Yamane, T. (1967). *Statistics: An introductory analysis* (2nd ed.). New York, NY: Harper and Row.
- Zou, S., Taylor, C. R., & Osland, G. E. (1998). The EXPERF Scale: A cross-national generalized export performance measure. *Journal of International Marketing, 6*(3), 37–58. Retrieved from <http://tinyurl.com/hm552tr>
- Zou, S., & Stan, S. (1998). The determinants of export performance: A review of the empirical literature between 1987 and 1997. *International Marketing Review, 15*(5), 333–356. doi: 10.1108/02651339810236290