

NAVAL ORDNANCE

Learning Outcome:

After the class discussion, the students are expected to:

- Be able to know the different naval ordnance terms
- Be able to distinguish explosive ordnance from inert ordnance

A. DEFINITION OF TERMS:

1. ORDNANCE - comprises the physical equipment pertaining to weapon. Classified as:

a. Explosive Ordnance - including such elements as:

1) Gun Ammunition - the complete assemblage of the component parts of ammunition details which makes up a round or a charge to any type of gun.

2) Torpedo - a self-propelled underwater missile use against ships and submarines.

3) Mines - are typically static weapon use to hinder enemy operations.

4) Bomb - covers all missiles dropped from aircraft, except torpedoes, mines and guided missiles.

5) Rocket - a self-propelled weapon whose absence of recoil makes it particularly suitable for firing from small craft or aircraft.

6) Guided Missiles - are new weapons which can travel great distance with heavy load and contain their own guidance.

7) Depth Charge - are thin walled container filled with relatively heavy charge of explosives and designed to explode at a predetermined depth or by the charge action of an influence type fuse.

8) Projector Charges - Similar to rockets and are used against submarines and close landing supports.

9) Chemicals - used to describes the variety of solid and gases which can be fired in projectiles from guns and mortars or dropped from aircraft. Used for screening, harassing etc.

b. Inert Ordnance - includes projecting devices such as:

1) **Guns** - typically consist of a tube closed at one end from which a projectile is fired by the burning in an enclosed space of the propellant charge.

2) **Launchers** - used to launch rockets or a device for head thrown missiles or anti-submarine weapons.

3) **Projectors** - used to project DC, projector charges, etc.

4) **Release Gears** - one type of track use to drop DC from the stern of a ship.

2. **GUNNERY** - the art and science of using guns to include the operations and control of all elements of armaments.

3. **BALLISTICS** - the science of projectile's motion classified as;

a. Interior Ballistics - pertains to the motion of the projectile inside the gun bore.

b. Exterior Ballistics- pertains to the motion of projectile outside the gun bore or the action of the projectile in flight.

4. **FIRE CONTROL**- the practical application of exterior ballistics and the methods and devices used to control the guns and other weapons.

5. **CALIBER OR GUN**- the diameter of the bore measured between the top of the lands and it is expressed in inches or millimeters.

6. **MOUNT**- support and secure the gun to the ship's structure and provides for the train and elevation.

7. **TRAIN**- the position of the axis of the gun bore in azimuth as measured from the ship's centerline.

8. **ELEVATION** - the angle that the gun bore axis makes with the deck measured in a plane perpendicular to the deck.

9. **RECOIL** - the force tending to push the gun to the rear as the projectile is discharged. It is the gun's reaction to firing.

10. **COUNTERRECOIL** - the forward movement of the gun after recoil which return the gun into battery or original position.

11. **IN BATTERY** - gun is said to be in battery when the gun is in its firing position. A gun moves out of battery during recoil and returns to battery during counter recoil.

12. **AUTOMATIC GUN** - guns in which some of the energy of explosion of the propellants is used to open the breech, eject the empty case and automatically load another round. Automatic gun can continue to fire as long as there is enough supply of ammunitions and trigger is pressed.

13. **SEMI-AUTOMATIC GUNS** - guns in which some of the energy of the explosion of the propellants is use to open the breech, eject the empty case, and automatically closed the

breech when another round is loaded either by hand or by auxiliary equipment.

14. **NON-AUTOMATIC GUNS** - guns in which none of the energy of the explosion of the propellant is used to perform breech opening or loading and unloading functions.

15. **AXIS OF THE GUN BORE** - a straight line passing through the center of the gun bore

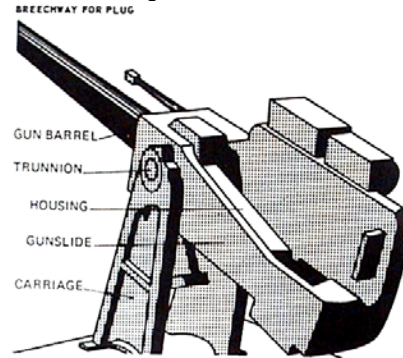

GUN AMMUNITION RECOGNITION AND PROJECTILE IDENTIFICATION

Learning Outcome:

After the class discussion, the students are expected to:

- Be able to know the different components of gun ammunition
- Be able to recognize the system of color coding

A. Basic Components of gun ammunition:

1. **Projectile** - contains the burster charge, fuze and/ or tracer.

2. **Propelling charges** - explosives that propels the projectile out of the gun bore.

3. **Primer** - initiates the burning of the propelling charges.

B. Gun ammunition is recognized by the information; ammunition lot number (ALN) stenciled/printed on their boxes and powder tanks through series of letters.

1. B - series for 5-inch gun ammunition
2. P - series for 3-inch gun ammunition
3. U - series for 40MM gun ammunition
4. Z - series for 20MM gun ammunition

C. Identification of projectile:

1. **By color** - which identify the primary role of the projectile and maybe in the form of an overall body color or if the projectile is colored green (old system) or olive drab (new system) it will have a 50MM (2") wide role band.

System of Color Coding:

a. For 3 -inch and larger caliber projectiles, colors are applied as overall body. Nose fuze and rotating band are not painted.

Color	Interpretation
Yellow	High Explosive
Brown	Low Explosive
Black	Armor Piercing
Silver/Aluminum	Counter measure
Light Green	Smoke/Marker
Light Red	Incendiary
White	Illuminating
Bronze	Drill/Inert/Dummy
Blue	Practice/Target
Orange	Exercise/Recoverable
Gray	Toxic or Irritant Agent

Non-significant color

Olive drab	All ordnance
Black	For lettering
White	For lettering

b. **Burster charge Color** - painted one (1) caliber from the nose of the projectile or from the base of the nose fuze.

Burster Charge	Band Color
Explosive D	Yellow
Composition A	Medium
Inert material w/ color burst unit	Slate
Inert Material or Empty	Red

Illuminating, Chemical and Window Not painted with buster charge or load. Area painted the same as the body color.

c. In addition to the body color and the buster charge color, projectile were marked to indicate certain characteristics such as the presence of tracer, dye load or chemical filler.

2. **By code lettering** marked to indicate characteristics such as the presence and code of the tracer, dye load, a color burst unit and chemical filler.

Projectile 3-inch & larger are lettered on the body by the manufacturer with the following information:

Caliber and type of projectile

Ammo Lot Number.

Mark & Mod of fuze (SD or NSD).

Manufacturer's initials.

Mark & Mod of the projectile

Serial Number.

Mark & Mod of ADF (if applicable).

Year of manufacture.

Mark and Mod of Illum load or W Load (for ILUM and W only).

PN STANDARD SHIPBOARD NAVAL GUNS

Learning Outcome:

After the class discussion, the students are expected to:

- Be able to recognize some of the PN shipboard standard guns and their characteristic
- Be able to enumerate the different gun personnel and their functions

The standard shipboard naval guns currently available in the PN inventory are mostly of the U.S.-made minor caliber guns - the **3-inch 50 caliber dual-purpose guns, 40MM** and **20MM anti-aircraft guns**. These are the types of armaments installed in patrol combatants and naval auxiliary ships which were acquired by the Philippine government from the U.S. at the end of World War II. Since their acquisition, the PN has developed the technical expertise in maintaining and extending the operational serviceability of these guns.

During the late 70s, the PN has acquired a relatively modern weapon system as part of its modernization program, the **30MM Emerlec guns**, which are now installed in some of its newly-acquired or newly-constructed patrol gunboats. Some modern **belt-fed 20MM guns** have also replaced the old 20MM AA guns. In line with the enactment of the AFP Modernization Law, plans are in the offing for the PN to acquire some of the latest gun systems, such as the **Oto Melara 76MM/62 caliber dual-purpose**, rapid-fire guns and the **Bofors 40MM AA guns**.

Characteristics of Naval Guns in the PN Inventory

a. The 3-inch 50 Caliber (3"/50) Single Gun

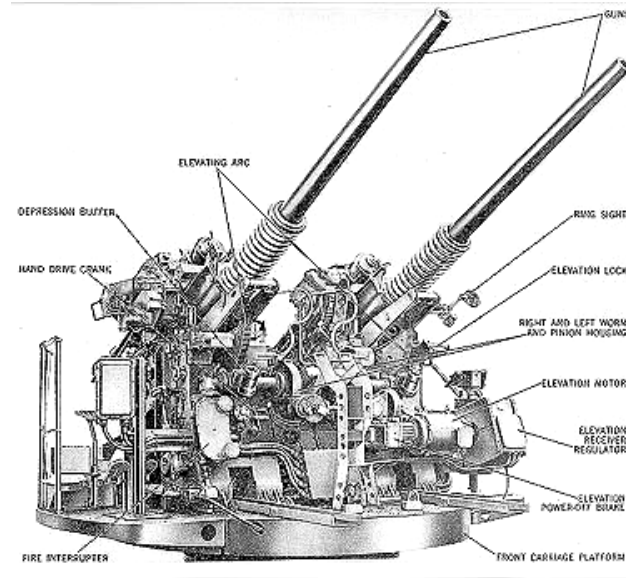

The 3"/50 gun is a pedestal mounted, single or semiautomatic firing, dual-purpose gun designed for action against surface and air targets.

This was developed by the U.S. towards the end of World War II to combat high altitude bomber aircraft and replace the 40MM and 20MM AA guns.

The gun is air-cooled, recoil operated and uses a fixed type of ammunition.

It can be fired electrically by means of a solenoid key or manually through a firing foot pedal connected to the gun by mechanical linkages at the rate of 20 rounds per minute.

The gun is provided with a manual as well as telescopic gun sights and sight setting mechanism to aid in hitting the target and a fuze setting mechanism for setting the projectile's mechanical time fuze.

The following are other important data about the gun:

Weight of the gun	- 7,817 lbs
Muzzle velocity	- 2,700 ft/sec
Rifling	- right-hand twist
Number of grooves	- 24
Length of recoil	- 10-11.5 inches
Maximum horizontal range	- 14,600 yards
Maximum vertical ceiling	- 29,300 feet
Effective range (horizontal)	- 8,000 yards
Effective range (vertical)	- 4,000 yards

The 3"/50 single gun mount is normally manned by a gun crew of nine (9) personnel, maximum, and seven (7), minimum. These personnel with duties indicated are as follows:

a) **Gun Captain** - he is in charge of gun crew directing the operation of the gun and is provided with sound-powered telephone (SPT) to communicate and take orders directly from the Gunnery Control Officer. He takes station by the hand-operating lever at the right side of the breech mechanism of the gun.

b) **Pointer** - he operates the hand wheel to elevate and depress the gun and keep it pointed in the position angle of the designated target using the manual gun sight or by setting the horizontal crosshair of the telescopic gun sight to the target in coordination with the Trainer and fires the gun when ordered. He takes station to the left seat of the gun.

c) **Trainer** - he operates the hand wheel to move the gun to the left or right and keep it trained in the direction of the designated target using the manual gun sight or by setting the vertical crosshair of the gun sight to the target in coordination with the Pointer. He takes station to the right seat of the gun.

d) **Sight Setter** - he operates the range and deflection scales of the sight setting mechanism as directed and repeats all orders to control. He takes station at the sight setting platform on the left side of the gun at the back of the pointer. In case none is assigned, the Gun Captain acts as the Sight Setter.

e) **Fuze Setter No. 1** - he operates the fuze setting mechanism or in the absence of such mechanism, provides himself with a hand wrench for adjusting nose fuze setting of the projectile. He takes station at the fuze setting platform on the left side of the gun. He may be the only Fuze Setter assigned, hence, he should take one round from the ammunition locker, take station at the fuze setting platform on the left side of the gun to set the fuze and prepare to pass the round to the Second Loader.

f) **Fuze Setter No. 2 (or Third Loader)** - he normally takes out one round from the ammunition service locker for setting the fuze and prepares to pass the round to the Second Loader. He also takes station at the fuze setting

platform in front of the Fuze Setter No. 1 on the left side of the Second Loader.

g) **Second Loader** - he normally stands by to receive the round from the Third Loader and prepares to pass it to the First Loader. He takes station in front of the Third Loader and to the left of the First Loader.

h) **First Loader** - he normally stands by to trip the salvo latch and receive the round from the Second Loader and prepares to ram the round into the gun. He takes station to a place behind and a little to the left of the gun with his left foot just beyond the danger circle.

i) **Hot Shellman** - he prepares to catch the ejected hot empty shell coming out of the gun as soon as it is fired. He takes station to a place behind and a little to the right of the gun convenient enough for him to do his job wearing asbestos gloves.

40 Millimeter Anti-Aircraft Gun(40MM AA)

The 40MM AA gun is a single or automatic firing (rapid firing), recoil operated gun designed for action against dive bombing aircraft or low flying aerial targets but maybe used against surface targets.

It maybe a single barrel (Army type), manually (local control) operated, air cooled gun; or, a twin or quadruple barrel (Navy type), manually or automatically (local or gun director control) operated, water cooled guns equipped with power drives for electric or electric/hydraulic operations.

This gun uses clip-feed ammunition, consisting of four (4) rounds, which are fired electrically by the gun director firing key and/or manually by pressing the firing foot pedal at the rate of 130-150 rounds per minute.



The gun is provided with manual gun sights for giving the necessary lead to allow for target motion during the time of flight of the projectile and also to provide for quick changing of the lead as the position of the target changes.

The following are other important data about the gun:

Weight of the gun	- 2,300 lbs
Muzzle velocity	- 2,830 ft/sec
Rifling	- right-hand twist
Number of grooves	- 16
Length of recoil	- 7.5 - 8 inches
Maximum horizontal range	- 11,000 yards
Effective range (horizontal)	- 5,000 yards
Effective range (vertical)	- 2,000 yards

The 40MM AA gun is manned and operated by a gun crew composed of seven (7) members for a twin mount plus two (2) more for each mount with a gun director Mark 51 and five (5) members for a single mount. A quad mount would need as much as 12-15 personnel.

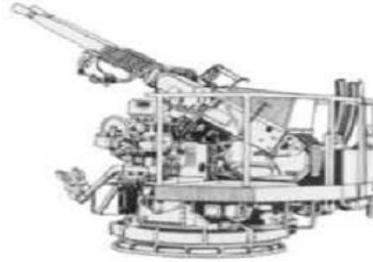

20 Millimeter Anti-Aircraft (20MM AA) Gun

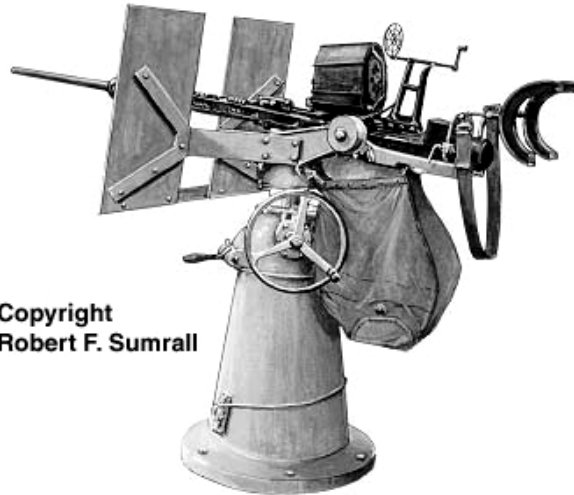

Copyright
Robert F. Sumrall

The 20MM AA gun is a single or twin barrel, pedestal mounted, automatic firing, magazine-fed gun designed for action against low-flying aerial torpedo attack aircraft but can also be used against surface targets.

It is air-cooled and blowback operated wherein the barrel does not recoil but the breechblock is never locked and in constant motion at the instant the round is fired.

The force of counter-recoil is being checked by the explosion of the next round.

The gun maybe provided with a manual gun sight or the Mk 14 electrically operated telescopic gun sight to aid the gunner in hitting the target.

The magazine is a cylindrical drum containing 60 rounds of ammunition which is placed on constant tension.

The gun can be fired electrically through a solenoid switch or manually by means of a trigger mechanism at a rate of 450 rounds per minute.

The mount is provided with a cocking devise (a wire rope or bar), an empty cartridge bag, a bracket that supports the shields, cradle spring and cradle.

The following are other data about the gun:

Weight of the gun	- 141 lbs
Muzzle velocity	- 2,725 ft/sec
Rifling	- right-hand twist
Number of grooves	- 9
Maximum range (45° elev)	- 4,000 yards
Effective range (horiz)	- 2,000 yards
Effective range (vert)	- 1,200 yards

The 20MM AA gun is manned and operated by a gun crew composed of a minimum of 3 personnel (single barrel gun) and a maximum of six (6) personnel (twin barrel gun).